

EECS 622 Project -
A Super-Het Receiver Design

Rev. A

Fall 2008

1. Summary

For this project, your team will **synthesize a wideband microwave receiver** design and analyze the design performance. This design includes the identification and specification of every microwave component, including LNA, preselection filter(s), mixer(s), local oscillator(s), IF amplifier(s), controllable attenuators(s), and IF filter(s).

You team will submit—by **5:00 pm on Friday, December 12**—a report that **a)** describes this design, and **b)** provides an analysis and verification of design specifications.

Your team will not build or in any way construct this receiver—this is a paper design **only!**

2. Technical Requirements

2.1 Receiver Requirements

The technical **requirements** for this microwave design are stated below.

2.1.1 RF Bandwidth

The **total** 3 dB-bandwidth for this microwave receiver shall extend from 3.0 GHz to 5.0 GHz.

2.1.2 IF Bandwidth

The **instantaneous** bandwidth of this microwave receiver shall be 2.0 MHz.

2.1.3 Channel Spacing

The adjacent signals in the RF spectrum can be as close as 5.0 MHz. In other words, the **gap** between adjacent signals can be as small as 3.0 GHz.

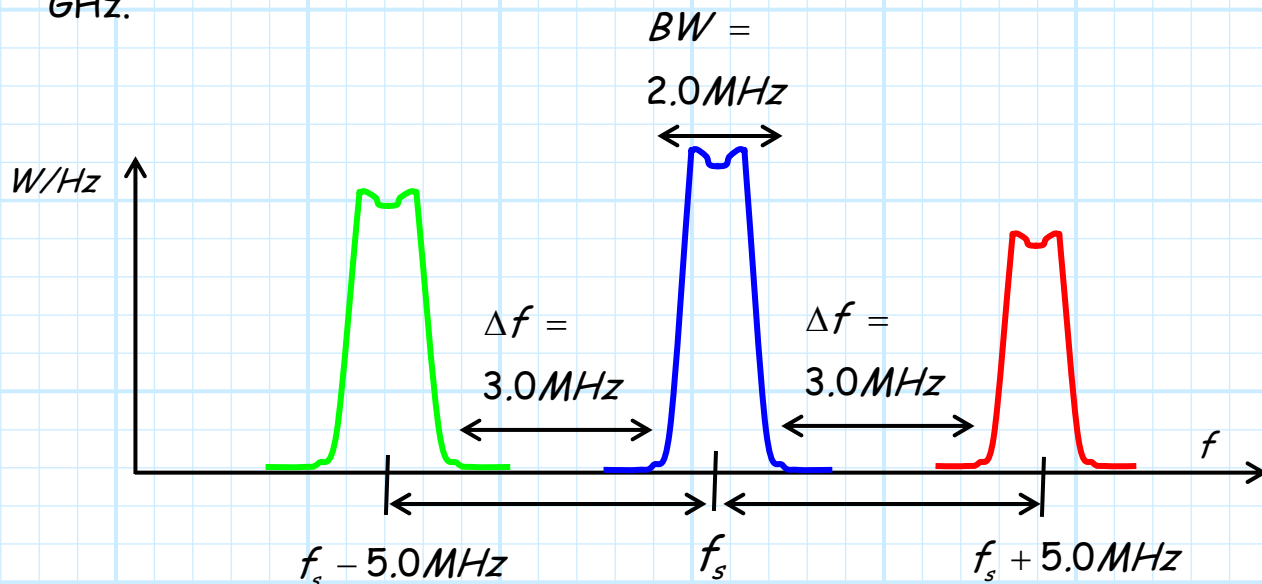

2.1.4 Selectivity

The IF filter shall attenuate **adjacent channels** by **at least 40 dB**.

2.1.5 Image Rejection

The RF **image band** shall be attenuated by **at least 50 dB**

2.1.6 Spurious Signal Rejection

All RF **signals** that produce spurious products **at the IF center frequency** shall be attenuated by **at least 25 dB**.

2.1.7 Sensitivity

The Minimum Discernable Signal shall be **less than -104 dBm**.

2.1.8 Total Dynamic Range

The **total dynamic range** of the receiver shall be **as large as possible**.

2.2 Detector Performance

This output of this receiver will be attached to a **demodulator** with the following specifications.

2.2.1 Detector Dynamic Range

The demodulator can accurately demodulate a signal if its signal power is **greater** than $P_D^{min}(dBm) = -50$ but **less** than $P_D^{max}(dBm) = -20$.

2.2.2 Detector Bandwidth

The demodulator can accurately demodulate a signal if its frequency is **less** than **500 MHz**.

2.2.3 Required SNR

The demodulator requires an **SNR** of at least 3.0 dB.

2.3 Design Constraints

These design **constraints** and criteria are likewise applicable.



2.3.1 Filter Bandwidth

The **percentage bandwidth** of any and all microwave filters must exceed 0.3%.

2.3.2 Filter Order

The order of every filter in the design must be **less than or equal to 7**.

2.3.3 Filter Part Count

The number of microwave filters in the **entire** receiver must not exceed 5 (i.e., must be 5 or less).

2.3.4 Local Oscillator Accuracy.

The stability (i.e., **accuracy**) of the local Oscillator must be **greater than** ± 3 ppm.

2.3.5 Local Oscillator Bandwidth.

The percentage bandwidth of an individual Tunable Oscillator (e.g. VCO) must be **less than 75%**. Remember, you can combine multiple oscillators (using a microwave switch) to make a single LO.

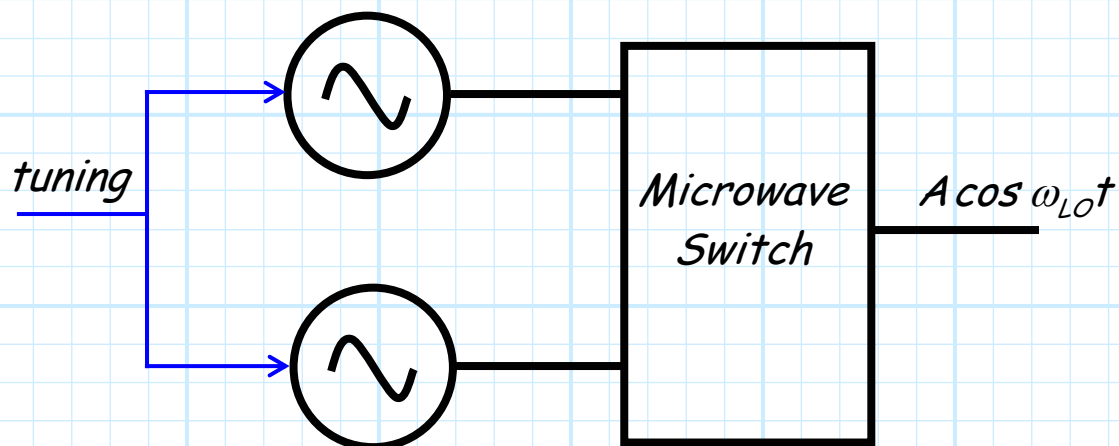

2.3.6 Cost

Receiver performance is much more important than cost, but of course we do not wish to **unnecessarily** increase cost.

3. Project Tasks

Your team will be required to **fully complete** each of the following tasks.

3.1 Receiver Design Synthesis

Use your knowledge of microwave components and receivers to synthesize a microwave receiver design that satisfies **every** technical requirement and constraint described in section 2.

This includes identifying specific components (amplifiers, mixers, attenuators, switches and couplers) **manufactured** by microwave vendors.

The **exceptions** to this are filters and oscillators. For the **preselector filter(s)**, the **IF filter(s)**, and the **Oscillator(s)** components, you must **write a complete specification**. In other words, do not select the parts from the web, but instead **write a specification** for these parts, suitable for **submission** to a component vendor.

Accordingly, write a **complete** specification (use each and **every** parameter from the class handouts!), specifying values that are **effective** yet **plausible**. For example, a filter insertion loss of 20 dB would not be **effective**, and an insertion loss of 0 dB would not be **plausible**.

3.2 Receiver Design Analysis

Once your team has completed its design, it must **analyze** the design in order to determine each and every specification of the attached Receiver Specification Sheet.

This process **verifies** your design synthesis procedure. Effectively you should pretend that someone has given you a completed super-hot design for which you **know nothing** other than the block diagram and each of the component specifications.

In other words, **pretend** that you don't know what the technical requirements were, or what decisions or procedures were used in the design synthesis. Using your knowledge of receivers **only**, analyze the

design and determine each of the receiver specifications (e.g., MDS or image rejection).

For **example**, say we need to determine the solution to the 2nd-order polynomial:

$$x^2 + x - 2 = 0$$

Applying our knowledge of quadratic equations, we find **two** solutions, $x = 1$ and $x = -2$. This procedure is analogous to design **synthesis**—finding solutions that satisfy specific requirements or constraints.

Now, we can **analyze** our solutions, to **verify** that they are correct:

$(1)^2 + 1 - 2 = 0$	$(-2)^2 + (-2) - 2 = 0$
$1 + 1 - 2 = 0$	$4 - 2 - 2 = 0$
$2 - 2 = 0$	$4 - 4 = 0$
$0 = 0$	$0 = 0$

Our solutions indeed **satisfy** the requirement!

Or, using a bit more **practical** example, say we have some input power of $P_{in} (dBm) = -70$ and we need to boost this power to a value greater than -58 dBm. We thus need an amplifier with some gain G . To determine this amplifier gain we write our **requirement** as:

$$P_{in} (dBm) + G (dB) > -58$$

Therefore we conclude that our amplifier gain **must** be:

$$\begin{aligned} G (dB) &> -58 - P_{in} (dBm) \\ &> -58 - (-70) \\ &> 12 \end{aligned}$$

We conclude that our amplifier must have a gain of **greater than 12 dB**. Say we find a suitable amplifier made by a manufacturer that provides a gain of **15 dB**. This gain is sufficiently large to meet our requirement, and so we select this amplifier for our design. This completes our design **synthesis**.

However, we must now perform a design **analysis**. How much power does the output of our amplifier provide?

$$P_{in} (dBm) + G (dB) = -70 + 15 = -55 dBm$$

Since this output power is greater than $-58 dBm$, we have **verified** the results of our design synthesis. Note in this case that the amplifier gain is 15 dB, **not** $> 12 dB$; and the output power is $-55 dBm$, **not** $> -58 dBm$.

→ **Do not confuse** requirements with specifications!

3.3 Receiver Design Documentation

After your team has synthesized and analyzed (i.e., verified) the receiver design, you must **document** your results.

3.3.1 Block Diagram

Your design "schematic" is a **detailed block diagram** of your receiver. **Every** component, but **only** the components of your design must appear in the block diagram. Each component in the block diagram must be labeled with the appropriate U number (i.e., unit number). Thus, **every** component must have a "block" in the diagram, and each "block" must signify only **one** component.

Note the block diagram shows how these devices should be **connected** (e.g., the output of the LNA is connected to the input of the preselection filter), so make sure you **place them properly**. You must analyze the design of **this** block diagram, not some other, more "ideal" design!

3.3.2 Component List

Make a **list** of that includes **every** component of your design. List the manufacturer part numbers as well . Assign a "**U number**" (i.e., unit number) for each and every component of your design. Provide a **brief description** of each component. For wideband filters identify the passband. For narrowband filters, identify the center frequency. For amplifiers, identify the gain. For example,

<u>U-number</u>	<u>Part Number</u>	<u>Description</u>
U1	LM-162	8 dB Low Noise Amplifier
U2		2.3GHz to 4.6GHz bandpass filter
U3	MAC4352	microwave mixer
U4	LM-356	14dB IF amplifier
U5		120 MHz center freq. bandpass filter
⋮	⋮	⋮

Note **every** component in your design must have a **unique** U number. For example if you use two attenuators, then each device must have its own U number.

3.3.3 Component Specifications

For **each** component in your design, you must compile a **component specification sheet**. This of course **includes** the specification sheets that you created for the filters and local oscillator, but **also** includes the "real" devices such as the amplifiers, mixer, attenuator(s), etc. For these real devices, **extract** the values from the vendor data sheets, and write a spec sheet of the form presented in the **class handouts**.



This spec sheet must be **complete**. In other words, if there are parameters on the handout that are not on the data sheet, then **provide your own** values that are both effective and plausible. If there are multiple devices on the specification sheet, **clearly mark** which device you are using!!! **Attach** also the **vendor data sheet** to your report, and underline or circle all values, plots, etc. that you used to determine your specification sheet.

Make sure that you write a **complete** specification, using the **correct units and terminology** for each parameter!

3.3.4 Report

Your team must provide a report that explains, documents, and justifies the receiver design. The format and requirements for this report are provided in the next section.

3.4 Caveats and Restrictions

Carefully read each of these caveats and restrictions!



3.4.1 Component Connectors

Do not worry about the **connectors** of the devices. In other words, it is fine if you use a connectorized mixer (e.g., SMA) with a circuit board (e.g., microstrip) amplifier.

3.4.2 Local Oscillator

In the "real world", the tunable oscillator(s) (e.g., VCOs) that you specify for your Local Oscillator will be **phase-locked**, in order to provide sufficient stability and phase-noise performance. Thus, you may specify

stability and phase-noise parameters that are associated with more **stable** oscillators such as crystal oscillators and DROs.

However, you need **not** specify, design, describe, or even consider the Phase-Locked Loop required to accomplish this phase-locking—just specify the microwave component of the LO—the oscillators and switches.

But **remember**, there are **restrictions** on the stability ($> \pm 3$ ppm) and the percent bandwidth ($< 75\%$) that can be used!!!!

3.4.3 Automatic Gain Control

Also in “the real world”, a stable **control loop** would be designed and constructed to control the variable attenuators in your receiver design.

However, you need **not** specify, design, describe, or even consider this control loop. You need only to specify the microwave components involved in the AGC, specifically amplifiers, attenuators, and a **directional coupler**.

3.4.4 Amplifiers

Make sure you use **low-power** (i.e., small-signal) microwave amplifier in your design. Do **not** use large, expensive power amplifiers used for transmitters (e.g., an amplifier with an output power of 2KW).

Likewise, make sure that your microwave amplifiers are microwave amplifiers and **not** simply microwave **transistors**!

3.4.5 Attenuators

Do **not** select **mechanically** adjustable attenuators! The attenuators that you use must be digital or voltage controlled.

4. Project Report

4.1 Goals

There are **three** things that you will be trying to accomplish with this report:

- 1) convince me that your design is a **fabulous** one—that it is well thought out and accurately analyzed.
- 2) convince me that you are a **fabulous** receiver designer that **understands** completely the concepts taught in this course.
- 3) convince me that you are a serious and professional engineering scholar, one who is proud of their work, and performs it in a complete, organized, detailed, precise and unambiguous manner.

4.2 Audience

Assume the audience for this report is a knowledgeable radio engineer (i.e., **me**), so make the report businesslike, technical, and to the point. You will not accomplish anything by including "**boiler plate**" material about the functions of a receiver or the genius of Edwin Howard Armstrong. Writing text about general information of this type is a **waste** of your time (and mine!).

4.3 Report Organization

The report must have these **four sections** in **this order**.

4.3.1 Design Description

This section provides all the information about **what** you did.

Here you provide a **detailed physical description** of your design. This section will include the detailed **block diagram**, the **parts list**, and the **receiver specification sheet**. Describe in general the design, as well as any outstanding characteristics, or disappointing limitations. Discuss the performance specs that you are most proud of, and the ones you are most disappointed in.

Present the **rational** for the choices you made in your design process. Chief among these are IF and LO **frequency selection**. Are there any downsides (i.e., problems or limitations) to your design? For example, have you made any design decisions that will adversely affect cost?

4.3.2 Design Analysis/Verification

You must provide **detailed analysis** of your design, showing the derivations and calculations used to determine the values in the **Receiver Specification Sheet**. For example, show how you determined the receiver compression point, noise figure, output noise, total gain, dynamic range, image rejection, etc.

This mathematical analysis must be clear and unambiguous, with each parameter and value defined by a **variable name**. You may use a spreadsheet or other computation tool to determine these values, but a spreadsheet is **not** sufficient for presenting your calculations (you must present me with your calculations!). I require that your **computations** be presented in your report.

I must be able to see **where** the error was made if your results or design are erroneous. I want to see all the **general equations** used, and then the **values** used for the **variables** in the equations, and **then** the numeric results of the equation.

You may put **detailed computations** in one or more **organized appendices**. These appendices can be **handwritten**. However, do not destroy the flow or organization of your report by providing **fundamental** information in

the appendix **only**. In other words, I do not want to have to search through the appendix to find fundamental design parameters—the appendix is for computation **details**.

Finally, make sure that you analyze **your** design and determine the specifications for it. Do not confuse the **requirements** (e.g. $MDS < -100$ dBm) with the MDS of **your** design! Moreover, do not assume that since “I used the right equation” that your result leads to acceptable performance. **VERIFY** that your receiver design does indeed perform the way you expected it to!

Although each and every item in the Receiver Specification Sheet must be verified in the manner and detail described above, there are three items that are particularly important.

4.3.2.1 AGC and Receiver Gain Verification

Verify by analysis that you have selected the proper **AGC attenuation**. Determine the **receiver gain** when the AGC is at both its minimum and maximum attenuation states. Show that the minimum and maximum RF input signal power (i.e., MDS and P_{in}^{sat}) will in fact appear within the dynamic range of the detector.

4.3.2.2 Image Rejection Verification

Verify by analysis that you have achieved the image rejection value stated in your Receiver Specification Sheet. To do this, you must determine the RF image bands associated with each and every tuning solution (e.g., preselector band). You then must determine the “worst case” image frequency (e.g., the frequency closest to the preselector passband).

From this, you can determine (and must show!) the normalized frequency α for this worst case frequency, and show then show that **your**

preselector filter will attenuate that frequency by at least the value of the receiver image rejection in **your** receiver specification sheet.

If you have **multiple** preselector filters, you must accomplish this for **each and every one of them** (note the "worst case" image frequency will be different for each filter). If you have two conversions (i.e., two mixers), this verification must likewise be achieved for each conversion.

4.3.2.3 Spurious Signal Rejection Verification

Verify by analysis that you have achieved the spurious signal rejection value stated in your Receiver Specification Sheet. To do this, you must determine the frequencies of all RF signals that could create a spurious signal at the IF center frequency. You then must determine the **two** "worst case" frequencies. (e.g., the frequencies closest to the preselector passband).

From this, you can determine (and must show!) the normalized frequencies α for these worst case frequencies, and show then show that **your** preselector filter will attenuate those frequencies by at least the value of the spurious signal rejection in **your** receiver specification sheet.

If you have **multiple** preselector filters, you must accomplish this for **each and every one of them** (note the "worst case" RF frequencies will be different for each filter). If you have two conversions (i.e., two mixers), this verification must likewise be achieved for each conversion.

4.3.3 Conclusion

Remind me again why you should receive an excellent score.

4.3.4 Appendix

In the back of the report place these **appendices**:

Appendix A: Provide the specification sheets for each component in your design. Make sure you mark precisely, completely and unambiguously the component which you are specifying, including the **U-number!** Place these component spec sheets in order of their U-number (i.e., U1, U2, U3, ...).

Appendix B: Provide the **vendor specification** sheets for the manufactured microwave components. Again, try to select components with detailed data sheets (but do **not** attach **mechanical** drawings!). Make sure you highlight or circle the values, plots, tables etc. that you used to determine the values on your own spec sheet. Also, if more than one component is listed on the spec sheet, mark specifically and unambiguously which component you used in the design.

Appendix C: Any detailed handwritten computations. However, these computations must be **a) neat, b) organized, and c) referenced** in the main body of the report.

4.4 Report Format

The format of the report is left to each individual, However, it must be well **organized**, and **professionally** presented.

The report should flow from one section to another as one **continuous narrative**. Often I receive a set of independent pieces, stacked together and called a report—do **not** do this! To this end, **all** figures, tables, and appendices should be labeled, numbered, and titled **and** referred to in the report. For example, "Table 2 provides the specifications for...", or "The details of the computation can be found on page 3 of Appendix C".

Likewise, the titles of each figure or table must be **descriptive**.

A descriptive title: Performance specifications of component U4, a wideband microwave mixer.

A non-descriptive title: Component Specifications

5. Project Teams

You may work individually, or as a team with **one** other students. As a team, you will design the receiver, identify or specify all components, analyze the design, produce a block diagram, component list, and all specification sheets.

You must work **together as a team**. Attempts to "divide up" the work always results in **dismal failure**. The resulting report is at best inconsistent and confusing, and at worst contradictory and unreadable.

If at any time you wish to "**divorce**" your self from a team member, let me know. I will arbitrate and may split the group—choose you team members wisely!

6. Academic Misconduct

You **must not interact** with any **other teams (present or past)**. Each team must complete **independent** design and analysis. Any interaction between teams will be considered **academic misconduct**, and **will result in a failing grade** and other sanctions (e.g., **expulsion**) from the school of engineering!

The **only** exceptions to this are specific questions regarding the operation of computer tools (e.g., MatLab, Excel, Word, etc.).



Each team must prepare a report. Do **not** show your report to **anyone** else, and **do not** ask to see someone else's report (**present or past**). I view your **report** as a **take home exam**, and it is your job to convince me that **you** thoroughly understand receiver design. If I find that you have shared (it's so easy to tell) your report with another team, then all parties will receive a **failing grade**, etc.



Additionally (although I should **not** have to say this), you cannot **plagiarize** (i.e., **copy** text from a book, paper, or website). This **especially** includes previous year's reports. This likewise will be considered **academic misconduct**, and may result in a **failing grade** and other sanctions from the school of engineering.

7. Grading

The attached **form** will be used to evaluate each project.

EECS 622 Project Evaluation

Authors: _____

1. **Report organization clarity and professionalism** - Was the report well written and organized? Was it easy to understand and follow? Did the authors appear to take the assignment seriously and work hard to produce a professional product?

/25

2. **Completeness** - Did the report include **all** the required elements? Were all caveats and restrictions adhered to? Were all the tasks completed?

/20

3. **Design effectiveness** - Is the design effective and accurate? Does it appear to be designed by a knowledgeable radio engineer? Does it meet the technical specifications of the project?

/25

4. **Design analysis/verification** - Is the analysis of the design complete and unambiguous? Are the design equations and calculations clearly, completely, and unambiguously stated? Is the analysis correct? Did the author's appear to know **why** their observations and measurements were correct? ?

/30

Comments:

/100