

# Feasibility of Dynamic Spectrum Access in Underutilized Television Bands

Victor R. Petty<sup>\*</sup>, Rakesh Rajbanshi<sup>\*</sup>, Dinesh Datla<sup>\*</sup>, Frederick Weidling<sup>\*</sup>, Daniel DePardo<sup>\*</sup>,  
Paul J. Kolodzy<sup>†</sup>, Michael J. Marcus<sup>‡</sup>, Alexander M. Wyglinski<sup>\*</sup>, Joseph B. Evans<sup>\*</sup>,  
Gary J. Minden<sup>\*</sup>, James A. Roberts<sup>\*</sup>

**Abstract**— This paper presents the preliminary results from a feasibility study regarding the operation of secondary spectrum users within unused television spectrum. Television spectrum is known within the wireless communications community as being underutilized, making it a prime candidate for dynamic spectrum access. Nevertheless, the quality of this spectrum for enabling secondary transmissions has never been assessed. Two unique scenarios are examined: (i) the possibility of unlicensed devices interfering with digital TV reception, and (ii) the possibility of secondary users experiencing interference when operating within close proximity to television towers. With respect to the former, we investigate the critical operating parameters for developing the technical rules for device operation in bands adjacent to a digital television transmission. Regarding the latter, we examine, via measurement campaign, how non-ideal transmission properties of television broadcasts, including intermodulation and saturation effects, can potentially impair the performance of secondary transmissions.

**Index Terms**—Digital TV, spectrum measurements, spectrum white space

## I. INTRODUCTION

The growing demand for wireless services and applications shows no sign of slowing down. However, the current *command-and-control* regulatory structure for licensing spectrum has been unable to cope with the drastic growth demands of the wireless industry. This has given rise to an ‘artificial scarcity’ of usable spectrum, resulting in spectrum license price levels that are prohibitively expensive, preventing many small to medium size businesses from entering the wireless market. Numerous studies have thus begun to examine how licensed spectrum is actually used, with the goal of not only re-thinking the spectrum licensing regime but also opening certain underutilized ‘prime’ spectrum to unlicensed and licensed secondary usage. It has been shown that several spectral bands, including the television spectrum, are underutilized [1].

There has been regulatory and legislative activity that could allow new wireless devices to access TV band *white space*<sup>1</sup> on a per market basis. This approach, called *dynamic spectrum access* (DSA), allows unlicensed devices (UD) to transmit in parts of the spectrum unoccupied by licensed signals. On June 28, 2006, the Senate Commerce Committee adopted ‘The Advanced Telecommunications and Opportunity Reform Act of 2006’ (S. 2686), which built upon the May 2004 Federal Communications Commission (FCC) Notice of Proposed Rulemaking (NPRM) [2] allowing unlicensed devices to utilize unused spectrum in the TV band. This legislation requires the FCC to continue with rule making procedures governing the opening of TV channels 2-51 (54 MHz - 698 MHz) for use by wireless broadband services and other DSA enabled devices. The FCC proposal also includes the reallocation of TV channels 52 - 69 (698 MHz to 806 MHz) for public safety communications as well as for auction. The NPRM specifies that any devices certified to use TV *white spaces* should use agile or cognitive radio technology in a dynamic spectrum access (DSA) configuration, such that these devices would not interfere with primary rights holders, namely television broadcasters.

In a DSA approach, the “secondary” users must not cause any ‘harmful interference’ to the primary users as well as the other unlicensed users sharing the same portion of the spectrum. Since primary users hold exclusive rights to the spectrum, it is not their responsibility to mitigate any additional interference caused by unlicensed or secondary device operation. These devices will have to periodically sense the spectrum to detect primary or secondary user transmissions and should be able to adapt to the varying spectrum conditions for mutual interference avoidance [3].

The availability of underutilized TV spectrum is not disputed. Two technical issues remain, however, that require solutions from the regulatory and business communities. The regulatory community must determine the technical rules that secondary devices must use to prevent harmful interference with primary devices (i.e.

<sup>\*</sup> University of Kansas, Lawrence, Kansas

<sup>†</sup> Kolodzy Consulting, Centreville, Virginia

<sup>‡</sup> Marcus Spectrum Solutions, Paris, France

Manuscript received November 15, 2006. This work was supported by NSF grants ANI-0230786, ANI-0335272, and grants from the New America Foundation.

<sup>1</sup> White space is a commonly used term for underutilized spectrum.

DTV receivers). Additionally, the device manufacturing community must determine if cost effective devices can be created that operate efficiently and correctly (with respect to technical rules) in the RF environment created by DTV transmissions.

The primary technical rules of interest to the Federal Communications Commission are the emission and the out-of-band emissions (OOBE) rules. The device manufacturers must comply with these rules through the selection of appropriate modulation, amplifier, and filter characteristics in both the transmitter and receiver chains. The expected RF environment also has a direct impact on the receiver characteristics and thus must be well understood.

In this paper, we present a feasibility study of devices performing DSA in underutilized television bands when television signals are present. The study is divided into two parts. The first part addresses the potential impact that secondary user transmissions could have on the video quality of digital television receivers. The development of an unlicensed device testbed allows experimentation to be performed that can help determine the baseline emission levels that can be tolerated by DTV receivers. In the second part, we address possible interference scenarios that could occur when an unlicensed device operates in close proximity to a television transmitter. The overall objective is to determine the conditions in which both television and “white space” transmissions can co-exist with each other in the same spectral band.

The paper is organized into the following sections. Section 2 provides background on the dynamic spectrum access approach. Section 3 describes creation of an unlicensed device emulator and testbed that will help determine the viability of DTV broadcasts co-existing with UD operation. The operation of unlicensed devices in physical proximity to TV transmitters will be discussed in Section 4. Finally, Section 5 will offer concluding remarks and analysis.

## II. DYNAMIC SPECTRUM ACCESS BACKGROUND

Substantial research efforts are underway that aim to find efficient ways of utilizing the vacant portions of the TV spectrum using DSA techniques. The new IEEE 802.22 standard focuses on technical implementations that can accomplish spectral reuse without causing harmful interference to primary users [4]. Some of the important issues that have been addressed include the feature detection of TV signals [5], collaborative sensing for improved detection capabilities [6], detection of the presence of receivers in the vicinity of the unlicensed device [7], and effective methods for the unlicensed spectrum access in the TV band [8].

There is some debate on whether devices can operate within the underutilized spectrum without causing interference. Some claim that unlicensed devices will cause harmful interference to the primary users [9], while others argue that DSA can be done in a transparent manner [10] and can be safely implemented using the latest radio technology communications techniques [11]. Proponents of the DSA approach favor the TV band for several reasons: There is a substantial amount of unused spectrum available and the propagation properties in these frequency ranges are beneficial for long range mobile and line-of-sight communications [8]. Studies show that deterministic usage patterns in the TV band make accurate spectrum sensing possible [12].

However, there are several challenges for enabling the use of these bands. The presence of strong TV transmissions that occur spatially near the secondary user can lead to the generation of spurious signals, intermodulation products, and saturation effects in the vacant bands [13]. This could occur at the transmission source, at the DTV receiver, or at the secondary-use receiver. The unoccupied portions of the spectrum might also include spurious signals or be licensed for other purposes, such as public safety. In addition, the secondary device might potentially cause interference to primary users if spectrum sensing fails to identify the presence of a primary user. Finally, significant out-of-band power leakage from a secondary user’s transmissions could slip into the primary user’s band and cause interference.

To provide input to these debates and assess the challenges to DSA, the feasibility of unlicensed device operation in the TV spectrum needs to be studied. A comprehensive feasibility study must evaluate operational interference and performance from the perspective of both the secondary user (unlicensed devices) and the primary user (DTV receivers, public safety transceivers, etc.).

First, TV receiver interference caused by unlicensed devices needs to be properly evaluated. The need for a standardized procedure to measure the effects of interference on TV signals has been stressed before [14]. This is crucial if the regulatory community wishes to reach a consensus on operational limitations for unlicensed devices. The level of interference that can be considered *harmful*<sup>2</sup> varies with the TV receiver and unlicensed device technology. A standard procedure for testing the interference-limiting capabilities of devices must account for these different technologies, along with various spectrum environments and usage scenarios. Second, interference that unlicensed devices might face

<sup>2</sup> Interference levels that impact the operation of the TV receivers to such an extent that the received TV signal is severely degraded.

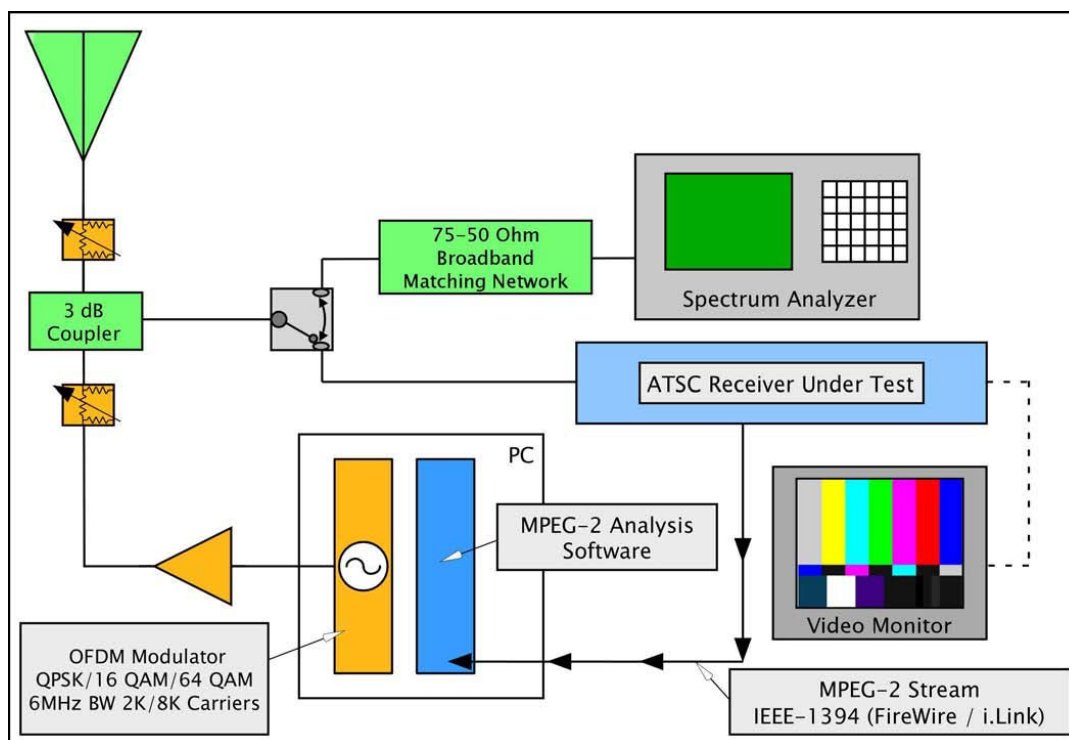

**Fig. 1 KU Unlicensed Device Emulator and Testbed (KUUDET)**

from operating both spatially and spectrally near TV transmissions to the secondary users needs to be evaluated. The results from these evaluations can be used to infer whether the available bandwidth and the current level of interference would allow unlicensed operation at the desired data rate or quality of service level.

An investigation studying the operation of public safety transmissions in the television band where both digital and analog television signals were present was conducted in [15]. Although several insights were obtained regarding the interaction between licensed and unlicensed transmissions, the investigation did not quantify the impact on the video quality of the television signal nor the effects of operating unlicensed devices at close distances to television transmitters.

### III. VIABILITY OF TV CO-EXISTING WITH COGNITIVE RADIOS

#### A. KU Unlicensed Device Emulator and Testbed

The KU Unlicensed Device Emulator and Testbed (KUUDET), shown in Fig. 1, is currently configured to simulate a Secondary Device (SD) operating in the 54 MHz to 806 MHz frequency range using OFDM modulation. UD emulation is accomplished using a desktop computer equipped with a PCI form factor modulator, which is capable of QPSK, 16 QAM, and 64 QAM, 2000 or 8000 carriers, and various code rates and guard intervals, with a 6 MHz transmit bandwidth. The

RF output level can be software controlled over a 31.5 dB range. Additional RF amplification and step attenuation is inserted into the UD transmit chain as required in support of specific test parameters. The UD output and the feed from a roof-mounted consumer grade directional TV antenna are fed into a 3 dB coupler, and the combined output is switched between a spectrum analyzer and the DTV (ATSC) receiver under test.

In the case of DTV receivers equipped with an IEEE-1394 (FireWire / i.Link) output, the KUUDET has the additional capability of MPEG-2 transport stream statistics analysis, which provides more precise DTV channel performance testing. Tests to date have focused on the effects of UD transmissions on consumer grade DTV receivers.

Although performance of the KUUDET has exceeded expectations, system enhancements are planned, and will include the addition of an 8-VSB (DTV/ATSC) modulated programmable signal source and a PCI form factor OFDM receiver, providing support for a wide range of UD and DTV experiments.

#### B. Types of Interference

When wireless transmissions operate in close proximity to each other in the frequency domain, there exists the potential for these signals to interact. This interaction can negatively impact the ability of a receiver to perfectly recover the desired signal. By characterizing

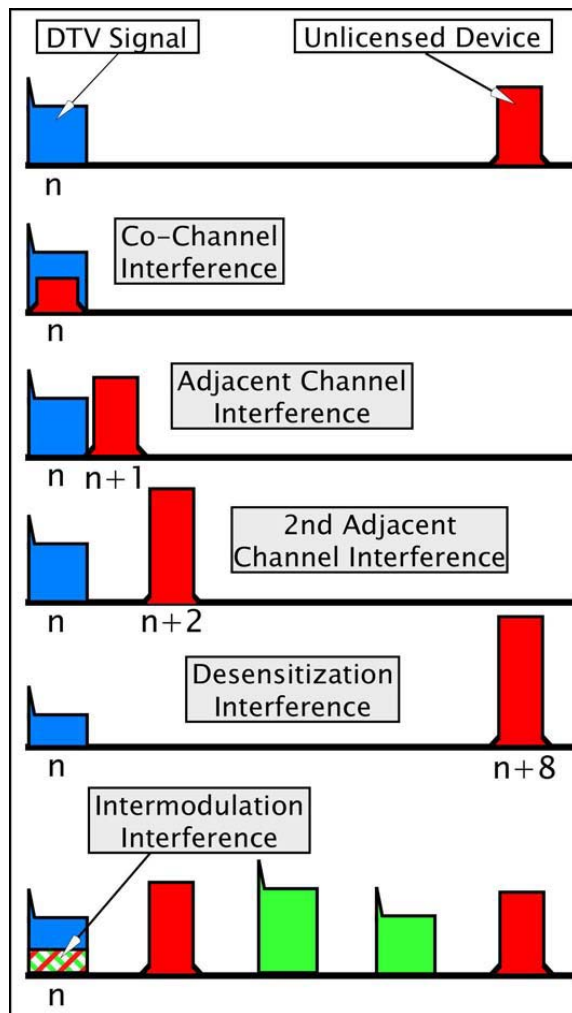

Fig. 2 Types of DTV Receiver Interference

the spectral characteristics of the signals located within a frequency range of interest, it is possible to classify the type of interference expected at the receiver. Five types of interference that could exist between a primary DTV signal and a secondary transmission in a dynamic spectrum access network are shown in Fig. 2.

The differences between each of these types of interference are based on the relative spacing between the two transmissions, and their relative transmission power levels. For instance, when the DTV signal spectrum is located at channel  $n$ , and the secondary transmission is also located at the same channel, this is referred to *co-channel interference*. In this scenario, the desired DTV channel would be severely corrupted by Secondary Device operation due to its inability to resolve the two signals. Another type of interference can occur if the secondary signal is located in an adjacent channel, such as channel  $n+1$ . In this case, the DTV signal may experience *adjacent channel interference* from the secondary signal since the transmitted spectrum of the latter may not be totally confined to its allocated

band. Note that as the amplitude level of the secondary transmission is increased, so does the amount of out-of-band radiation that could interfere with the DTV signal.

If the secondary signal is located further away from the DTV signal, such as the second adjacent channel, the impact of adjacent channel interference is substantially reduced, relative to secondary signals operating closer to the DTV signal, given the same power levels. However, if the power level of the secondary signal is increased, it is possible that some out-of-band radiation may interfere with the DTV signal. In fact, when the secondary signal is substantially stronger than the DTV signal and is located in the vicinity of a desired frequency, *desensitization interference* can potentially occur. In this scenario, the secondary signal overloads the receiver, inhibiting its ability to fully recover the desired DTV signal.

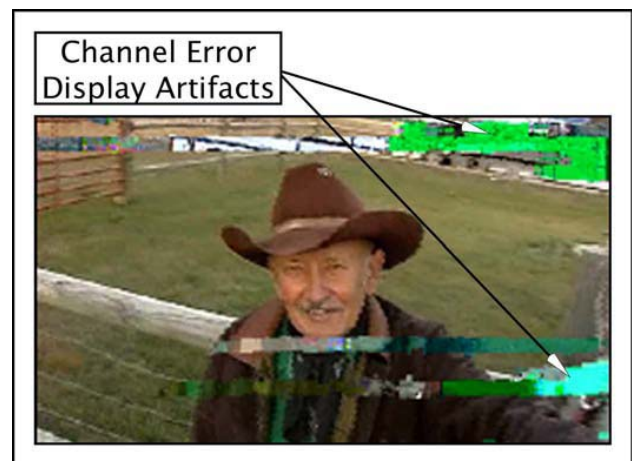

Fig. 3 Displayed Effects of DTV Channel Errors

Receiver *intermodulation interference* occurs when two or more signals are present within the same frequency range that are mixed in a receiver RF amplifier or mixer stage during non-linear operation, producing a signal that interferes with a desired signal. Consequently, these receiver-generated signals could prevent the display of the content of a desired DTV channel.

The visible effects of DTV receiver interference can range from mild error artifacts to complete loss of channel content display. Fig. 3 is an example of moderate display errors.

### C. Preliminary Observations

Initial experiments reveal that a relatively high UD channel power level is required before the output negatively impacts a DTV test receiver. The spectrum analyzer plot in Fig. 4 represents the UD Emulator output level required to create displayed errors in a DTV channel with the emulator tuned two channels away.

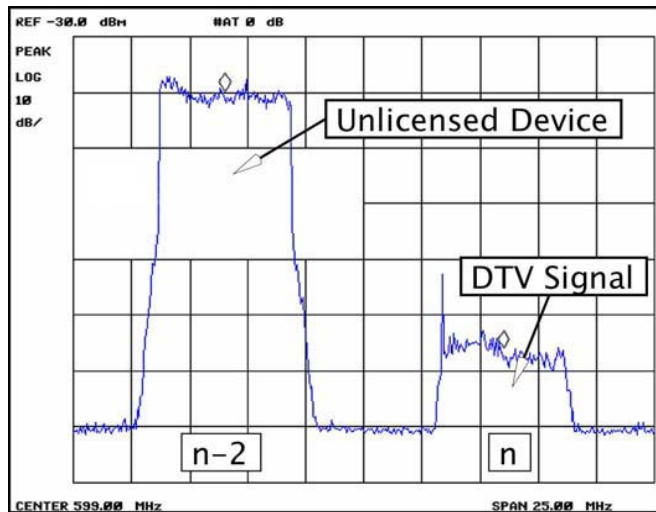

Fig. 4 Spectrum of input to DTV receiver

Initial adjacent channel and co-channel measurements are illustrated in Fig. 5. This shows the UD transmit levels (in dBm / 5.38 MHz BW) required to cause visible impairments to the DTV reception when the desired DTV signal is at the indicated level (most commonly in these tests, at the ATSC A/74 “Weak Desired” -68 dBm / 5.38 MHz) level. The ATSC Recommended Practice: Receiver Performance Guidelines A/74 document [16] was used as a reference to develop test procedures, as there is not yet a standard

for non-TV (ATSC/NTSC) signals. Three receivers were tested: (1) a 1999-vintage ATSC set-top tuner, (2) a recently manufactured midrange LCD digital TV, and (3) a recently manufactured but relatively inexpensive ATSC set-top tuner.

It is important to note that no additional filtering was applied to the output of the OFDM modulator. The measurements detailed in the full report [17] indicate that the performance achievable with filtering is comparable to that of the OFDM modulator card without filtering as used in the KUUDET.

TV band devices with more effective output filtering would potentially be capable of transmitting at higher power levels without inducing negative effects into a desired DTV signal than those reported in the measurements contained in Fig. 5 (with the exception of a co-channel situation).

A summary of the results is shown in the Fig. 5 plot and table. This is a plot of the results for the three receivers versus the A/74 threshold. In this test series, the desired DTV signal was set to a -68 dBm / 5.38 MHz level, which corresponds to the A/74 “Weak Desired” level. Each receiver was tested at the channel offsets shown (e.g., n+2), and the UD power levels that caused visible errors were recorded. These levels are shown in the plot versus the recommended A/74 profile, as well as in the table below. The Receiver #1 (1999-vintage set-top box) measurements are the purple squares, the

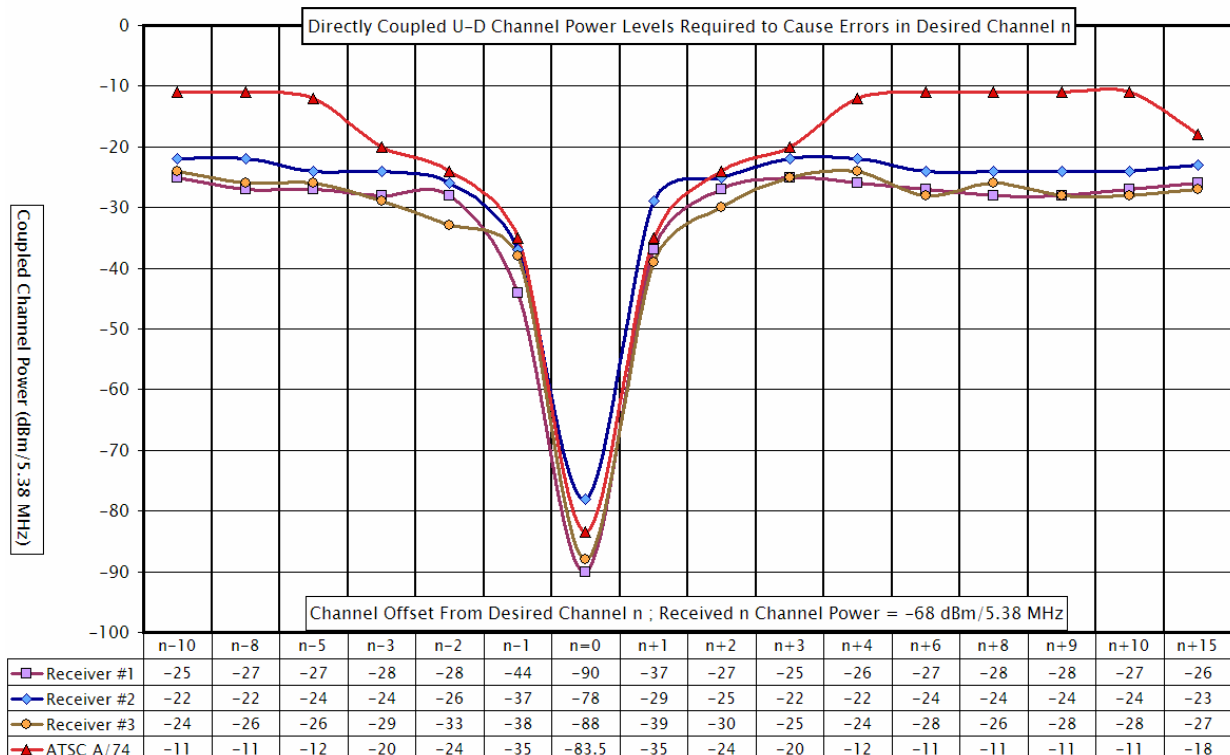

Fig. 5 - Example initial DTV receiver measurement results

Receiver #2 (LCD DTV) measurements are the blue diamonds, and the Receiver #3 (recent but inexpensive set-top box) measurements are the yellow circles. The A/74 profile is shown with red triangles.

The preliminary experimental results from a limited number of test receivers indicate that the proposed UD operation in the television band can be accomplished without significant impact upon DTV receivers in the vicinity. Further results and analysis for these preliminary experiments can be found in [17]. Experiments are ongoing and will be thoroughly reported in future publications.

#### IV. VIABILITY OF SECONDARY DEVICE OPERATION NEAR TV TRANSMITTER

##### A. Field Measurements

In order to study the interference experienced by a secondary device in close physical proximity to TV transmitters, three sets of spectrum power measurements were collected at various distances from a TV tower transmitting both analog and digital signals (Fig. 5). These measurements can be used in an evaluation of cognitive radio performance as well as help set guidelines on the effective operation of unlicensed devices in the vicinity of TV stations. Moreover, this experiment emulates a scenario where the unlicensed device is mobile and the spectrum characteristics change as the radio moves away from the TV station. The broadcast tower for the WIBW television station located west of Topeka, Kansas (USA) was selected because there were few transmitters nearby both geographically and spectrally and over 400 MHz separated its analog and digital stations. This allowed for the measurements taken to include unused surrounding channels such that any intermodulation or saturation effects would be clearly identified.

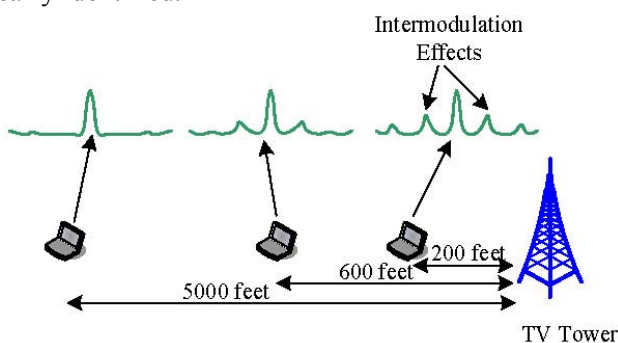

Fig. 5 Measurement Campaign

*Spectrum Miner*<sup>3</sup> is a software tool designed to automate the collection of spectrum utilization measurements. The software supports archiving measurements, sharing measurements with collaborators via a web interface and exporting data into analysis programs such as Matlab or Mathematica. Fig. 6 shows the measurement equipment used in the field. An omnidirectional disc cone antenna is connected to the input port of an IFR-2398 spectrum analyzer. The Spectrum Miner software is installed on a laptop computer and it controls the spectrum analyzer over an RS-232 or a general purpose interface bus (GPIB) connection.



Fig. 6 Field Measurement Setup

The measurements were collected on September 1, 2006 between 4:30–6:15 PM (US Central Standard Time), in TV channels 13 (analog television, 210-216 MHz, ERP<sup>4</sup>: 316 kW) and 44 (digital television, 650-656 MHz, ERP: 193 kW). As shown previously in Fig. 5, the measurements were collected at increasing line-of-sight distances of 200, 600, and 5000 feet from the WIBW TV tower. The GPS coordinates of the measurement locations in Topeka are listed in Table 3 while Fig. 7 shows the geographic location of the measurement sites. In order to study the impact of intermodulation and saturation effects on secondary transmissions, 12 MHz

<sup>3</sup> *Spectrum Miner* is developed by the *Kansas University Agile Radio Group*. More details on the *Spectrum Miner* program can be obtained in [18].

<sup>4</sup> ERP is an abbreviation for effective radiated power.

of bandwidth on either side of the TV channels was also recorded. Thus, the total bandwidth spanned by each measurement set is 30 MHz with a spectral resolution of 10 kHz. At each measurement site, 25 sweeps were recorded over the 30 MHz bandwidth for both the analog and digital TV channels. The measured power spectrum was averaged over the 25 sweeps. The plots of the average power spectrum measured at increasing distances from both the analog TV and the DTV towers are shown in Fig. 8.

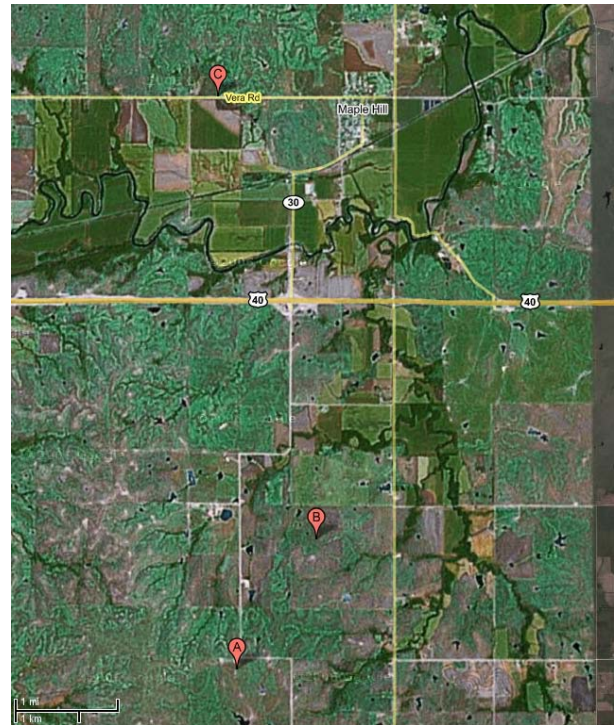
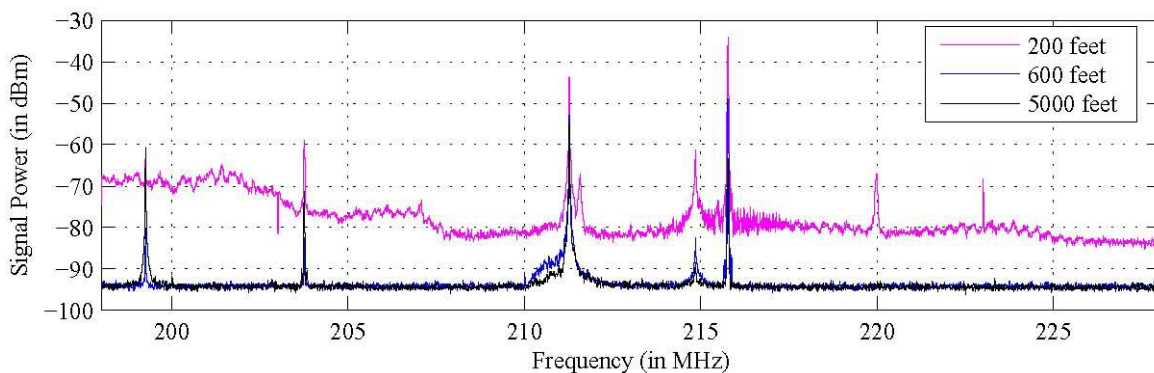

Fig. 7 Map of the measurement location

Table 1 Measurement Site GPS coordinates

Site	Coordinates	Elevation
A	39°00.408N, 96°02.946W	1298 ft.
B	39°01.565N, 96°02.914W	1090 ft.
C	39°05.261N, 96°03.169W	1000 ft.



(a) Analog TV Spectrum with channel 13 (210-216 MHz)

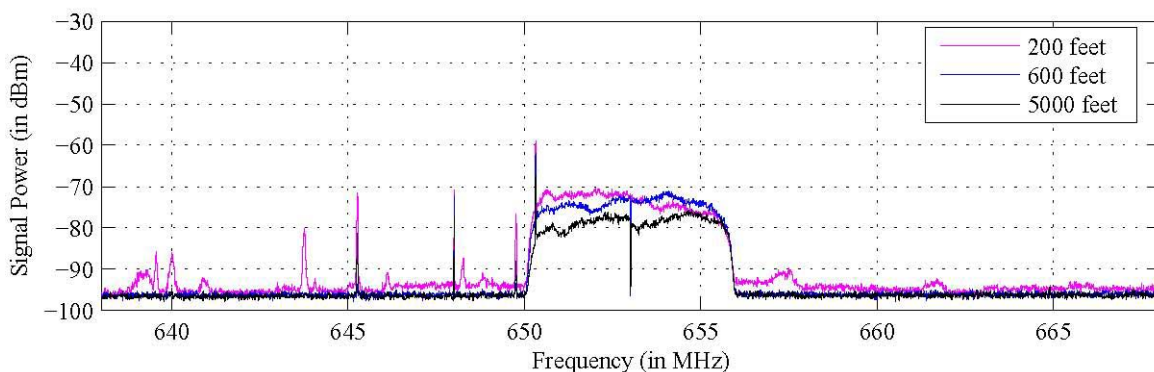

(b) Digital TV Spectrum with channel 44 (650-656 MHz)

Fig. 8 TV Spectrum Measurements

### B. Analysis

To analyze the impact of TV transmissions on the operation of unlicensed devices, we simulated UD operation in the 12 MHz bands adjacent to the TV channel. The UD was simulated transmitting OFDM symbols. The spectrum measurement data was processed to obtain the average noise power in the frequency channels adjacent to the occupied TV bands. The characteristics of the channel that the simulated OFDM device operated in were based on these actual average noise power statistics. A quasi-analytical error rate estimation approach was used in the simulation to determine the bit error rate (BER) performance of the OFDM system.

The system parameters for the OFDM transmissions are shown in Table 4. For the simulation, we considered a QPSK modulated OFDM system having 512 subcarriers each with a bandwidth of 10 kHz. The OFDM transmission utilizes the bandwidth of 5.12 MHz adjacent to the occupied TV band. Since the measurement sites were located in an open area with fewer obstructions in the outdoor channel, we assume a negligible effect of multipath signals on the system performance.

In our simulation, the probability of bit error was computed as [19]:

$$P_{be}(n_i) = Q\left(\sqrt{\frac{4S(n_i)}{N(n_i)}}\right)$$

$$P_{avgbe} = \frac{1}{512} \sum_{i=1}^{512} P_{be}(n_i)$$

where,  $N(n_i)$  is the average noise power measured at frequency  $n_i$ ,  $P_{be}(n_i)$  is the probability of bit error for the  $i$ -th QPSK subcarrier at frequency  $n_i$ , and  $P_{avgbe}$  is the probability of bit error for the OFDM transmission computed by averaging the error probabilities over all the 512 subcarriers.

**Table 2 OFDM Parameters**

Parameter	Values
Modulation	QPSK
No. of Subcarriers	512
Subcarrier Bandwidth	10 kHz
Overall Bandwidth	5.12 MHz

### C. BER Performance Results

In Fig. 8, the presence of spurious signals and the average noise level in the spectrum adjacent to the occupied TV bands 210-216 MHz and 650-656 MHz is of particular interest to us. The spikes of narrow bandwidth in the plots might represent the channel

activity of other licensed users such as public safety. The spurious signals, which might be other licensed users such as public safety radios or intermodulation products of the TV transmissions, can potentially interfere with the secondary OFDM transmissions and degrade the BER performance.

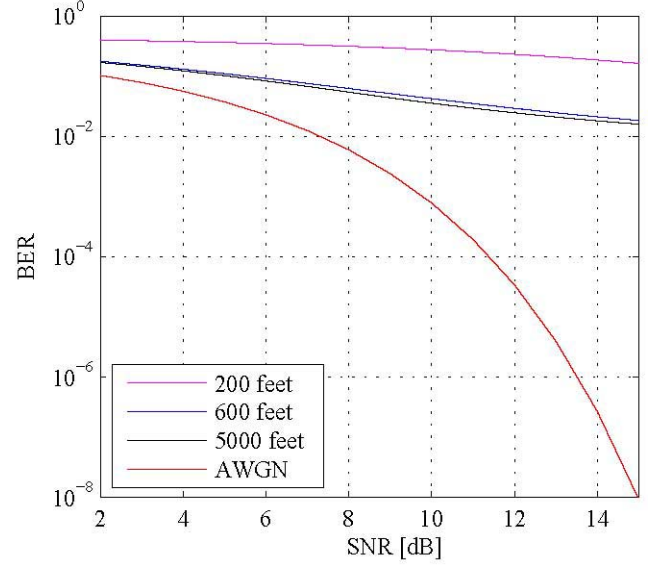

**(a) Analog Channel BER Plot**

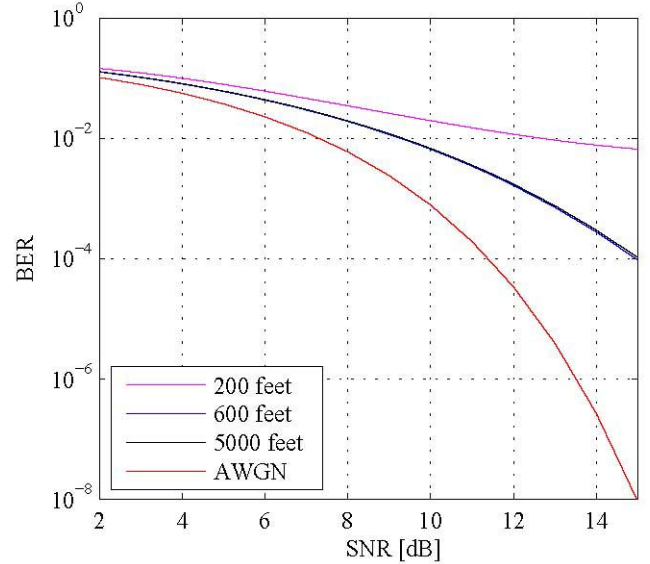

**(b) Digital Channel BER Plot**

**Fig. 9 OFDM Transceiver Error Performance in AWGN channel and vacant TV bands**

The measurements collected at a close proximity of 200 feet from the analog TV tower contain strong spurious signals. Moreover, the noise floor is quite high due to the saturation effects of strong TV signals at the receiver. At distances of 600 and 5000 feet, the spurious signals are weaker, and the average noise level is lower than -90 dBm. In the vicinity of the digital TV transmissions, the average noise level does not vary much with the distance from the TV tower and it is



below -90 dBm at all the three distances. There are several spurious signal spikes in the power spectrum measured at 200 feet from the DTV station.

The BER results for a simulated OFDM transceiver operating in an AWGN channel as well in the TV bands are shown in Fig. 9. The BER performance of the OFDM transceiver can be explained in terms of the varying levels of spurious signals and noise levels at the three distances from the TV tower.

Due to the presence of spurious signals, the performance in both the DTV and the analog TV bands is poor when compared with the AWGN channel case. In the vicinity of the analog TV band, the performance is worse at 200 feet from the tower. At distances of 600 feet and 5000 feet, the performance is comparable to the AWGN channel case at low SNR conditions of up to 3 dB. However, as the SNR increases there is no remarkable improvement in the performance, as the BER never drops below  $10^{-2}$ .

Better performance is obtained in the case of the DTV band. The performance is poor at 200 feet distance with not much improvement at high SNRs. However, the performance at distances farther away from the tower improves with increasing SNR and it drops to  $10^{-4}$  at an SNR of 14 dB. Moreover, at low SNR conditions, the performance at 600 feet and beyond is comparable to that in the AWGN channel. It should also be noted that there is no change in the performance for distances beyond 600 feet from the tower, due to the presence of spurious spikes that could be other licensed users.

## V. CONCLUSION

In this paper, we have presented a feasibility study of secondary transmissions in the TV spectrum. We have demonstrated that an unlicensed device can operate in an adjacent channel to a primary user in the TV band without causing significant levels of interference. We have also shown that while unlicensed device operation in the vicinity of a TV transmitter can result in poor secondary user performance results, operation at longer distances is relatively free of intermodulation or spurious signal effects, yielding better conditions for dynamic spectrum access.

Our preliminary experimental results support the claim that properly implemented unlicensed devices operating as secondary users in the television band can engage in dynamic spectrum access without significantly impacting DTV reception. Our hope is that this study, along with continuing work in this subject area at the University of Kansas, will be of value in regulatory discussions concerning spectrum policy decisions that will ultimately define access to a valuable national asset, the spectrum allocated to the television band.

## REFERENCES

- [1] M. A. McHenry, "NSF spectrum occupancy measurements - project summary." Shared Spectrum Company, Aug. 2005.
- [2] Federal Communications Commission, "Unlicensed operation in the TV broadcast bands." ET Docket No. 04-113, May 2004.
- [3] "The XG Vision: Request For Comments," tech. rep., BBN Technologies, version 2.0.
- [4] C. Cordeiro, K. Challapali, D. Birru, and S. Shankar, "IEEE 802.22: The first worldwide wireless standard based on cognitive radios," in *Proc. IEEE Int. Symp. New Frontiers Dynamic Spectr. Access Networks*, (Baltimore, MD, USA), pp. 328-337, Nov. 2005.
- [5] A. E. Leu, K. Steadman, M. McHenry, and J. Bates, "Ultra sensitive TV detector measurements," in *Proc. IEEE Int. Symp. New Frontiers Dynamic Spectr. Access Networks*, (Baltimore, MD, USA), pp. 30-36, Nov. 2005.
- [6] E. Visotsky, S. Kuffner, and R. Peterson, "On collaborative detection of TV transmissions in support of dynamic spectrum sharing," in *Proc. IEEE Int. Symp. New Frontiers Dynamic Spectr. Access Networks*, (Baltimore, MD, USA), pp. 338-343, Nov. 2005.
- [7] B. Wild and K. Ramchandran, "Detecting Primary Receivers for Cognitive Radio Applications," in *Proc. IEEE Int. Symp. New Frontiers Dynamic Spectr. Access Networks*, (Baltimore, MD, USA), pp. 124-130, Nov. 2005.
- [8] M. McHenry, "The Probe Spectrum Access Method," in *Proc. IEEE Int. Symp. New Frontiers Dynamic Spectr. Access Networks*, (Baltimore, MD, USA), pp. 346-351, Nov. 2005.
- [9] American Federation of Musicians, "Comments in response to ET docket no. 04-186," October 2006.
- [10] Wireless Internet Service Provider's Association, "Comments in response to ET docket no. 04-186," March 2006.
- [11] R. Rajbanshi, A. M. Wyglinski, and G. J. Minden, "Adaptive mode peak-to-average power ratio reduction algorithm for OFDM based cognitive radios," in *Proceedings of 64th IEEE Vehicular Technology Conf.*, (Montreal, Canada), Sept. 2006.
- [12] D. Cabric, S. M. Mishra, R. W. Broderson, "Implementation issues in spectrum sensing for cognitive radios," in *Conference Record of the Thirty-Eighth Asilomar Conference on Signals, Systems and Computers*, vol. 1, (Pacific Grove, CA, USA), pp. 772-776, Nov. 2004.
- [13] C. W. Rhodes, "Interference between television signals due to intermodulation in receiver front - ends," *IEEE Transactions on Broadcasting*, vol. 51, pp. 31-37, March 2005.
- [14] T. X. Brown, "An analysis of unlicensed device operation in licensed broadcast service bands," in *Proc. IEEE Int. Symp. New Frontiers Dynamic Spectr. Access Networks*, (Baltimore, MD, USA), pp. 11-29, Nov. 2005.
- [15] D. Prendergast, M. Guillet, B. Caron, Y. Wu, X. Wang, B. Ledoux, and S. Lafleche, "The effects of public safety mobile systems operations (in tv channels 63/68) on DTV and NTSC broadcasting," *IEEE Transactions on Broadcasting*, vol. 51, pp. 43-50, March 2005.
- [16] Advanced Television Systems Committee, "ATSC Recommended Practice: Receiver Performance Guidelines, Doc. A/74", June 2004.
- [17] D. DePardo, J. B. Evans, J. A. Roberts, V. R. Petty, A. M. Wyglinski, P. J. Kolodzy, M. J. Marcus, "Quantifying the Impact of Unlicensed Devices on Digital TV Receivers" FCC comment, New America Foundation Tech. Report, Jan. 2007
- [18] F. Weidling, D. Datla, V. Petty, P. Krishnan, and G. J. Minden, "A Framework for RF Spectrum Measurements and Analysis," in *Proc. IEEE Int. Symp. New Frontiers Dynamic Spectr. Access Networks*, (Baltimore, MD, USA), pp. 573-576, Nov. 2005.
- [19] J. G. Proakis, *Digital Communications*. New York, NY, USA, McGraw-Hill, 4th ed., 2001.