

# Examples of CMOS Logic Gates

See if you can determine the **Boolean expression** that describes these **pull-down networks**:

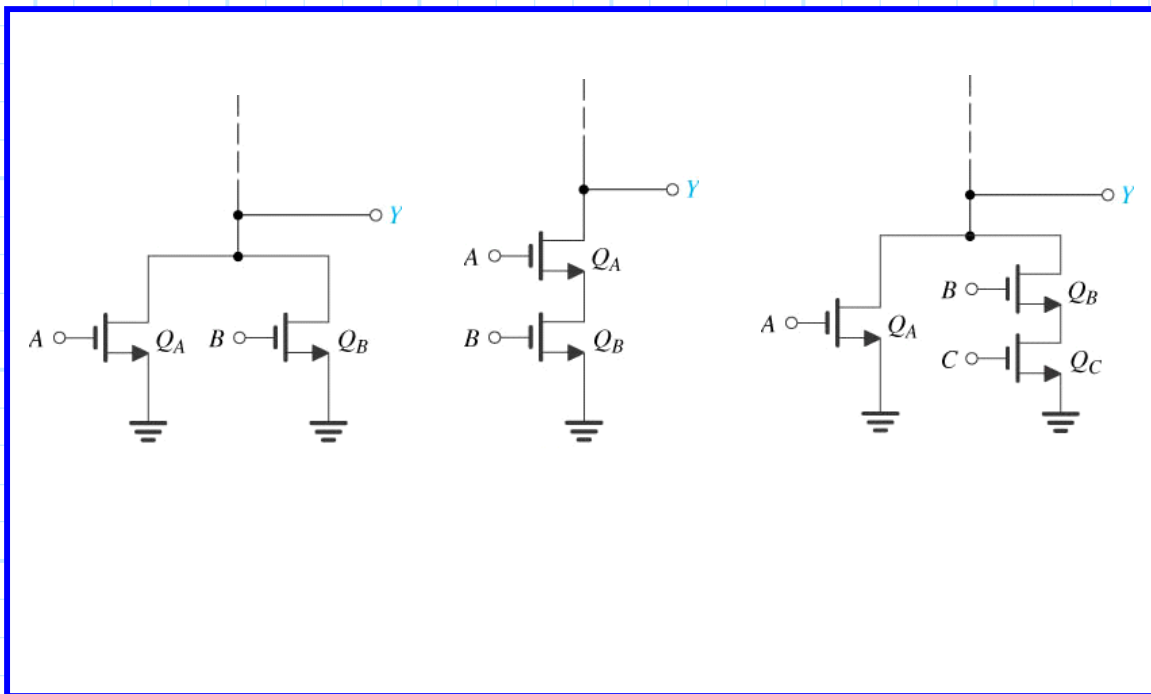

See now if you can determine the **Boolean algebraic expression** for these **pull-up networks**:

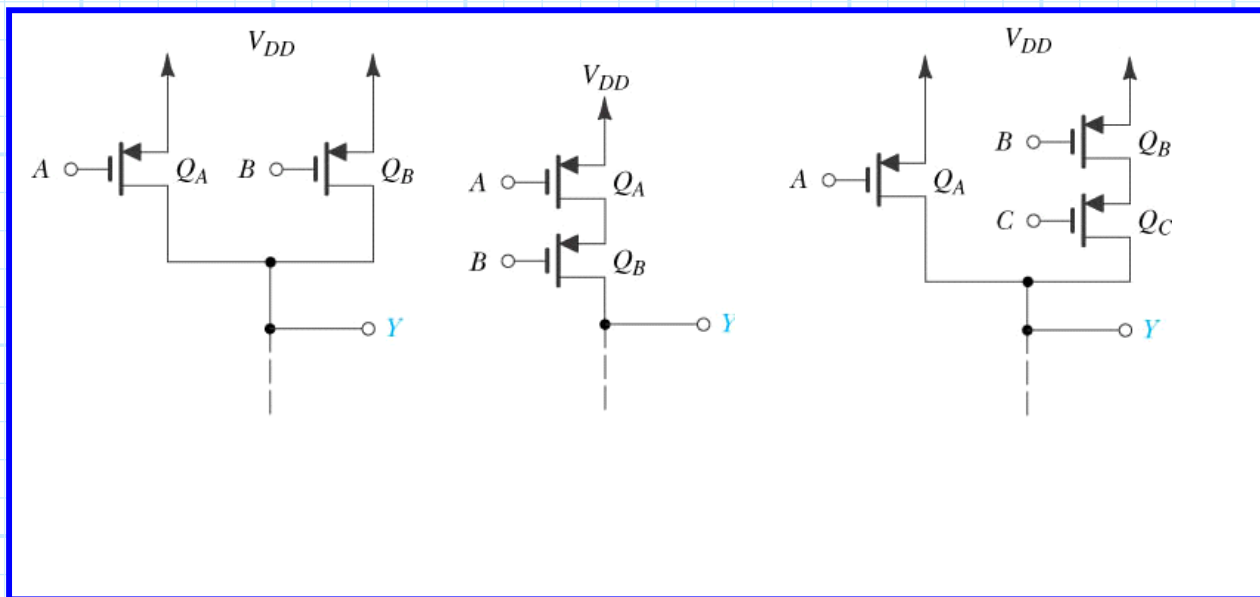

Now, we will make a simplifying change of symbols:

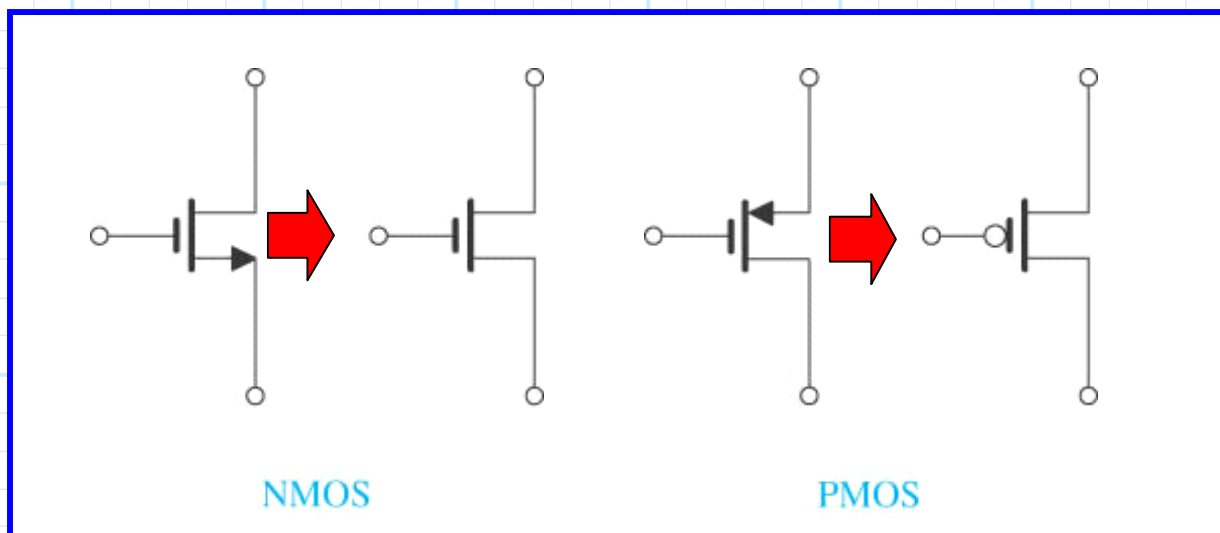

Effectively, these symbols represent the fact that we are now considering MOSFETs as **switches**, which can be placed either in an **open** state or a **conducting** state.

Note there are **two** kinds of "switches"—the ones that conduct when the input is high (i.e., **NMOS**) and ones that conduct when the input is low (i.e., **PMOS**).

And now consider **these** logic gates:

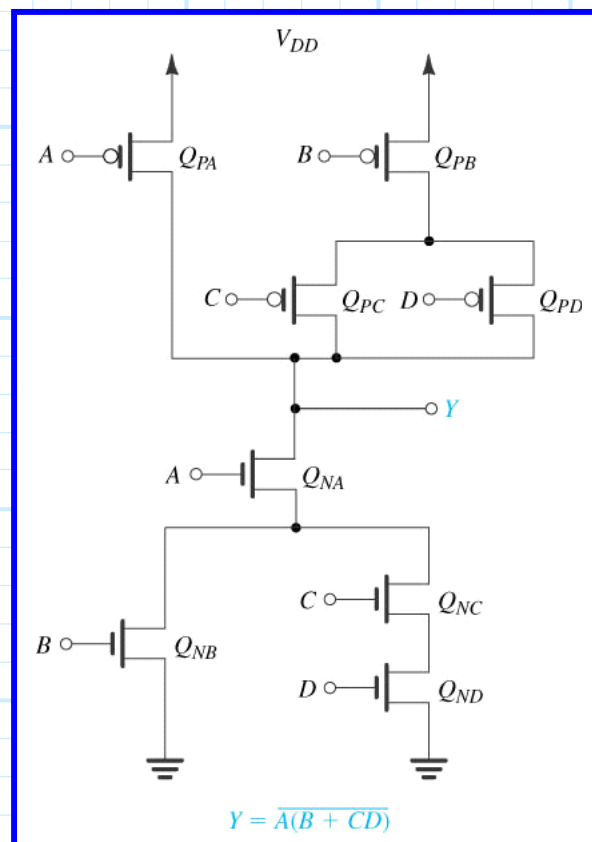
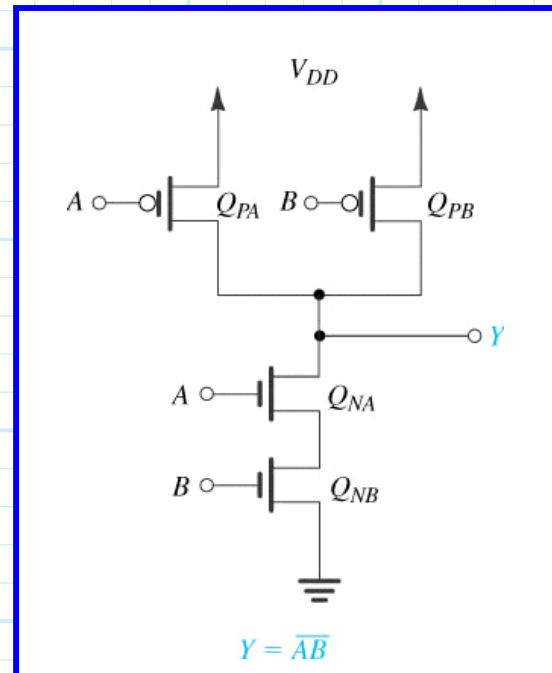
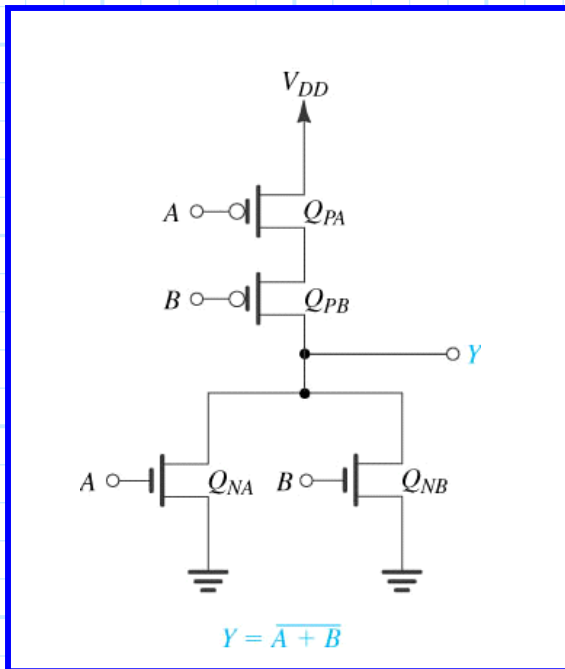

Note the PUN and the PDN for each of these circuits have **equivalent Boolean expressions** (make sure you see this!).